

17274S-EN

MRR

MODULAR RAIL RIFLE

SEMI-AUTOMATIC

OPERATORS SAFETY AND INSTRUCTION MANUAL



TABLE OF CONTENTS

	PAGE		PAGE
INTRODUCTION	1	FUNCTION TEST	13
NOTICES	1	AMMUNITION	14
WARNINGS	2	FILLING THE MAGAZINE	15
PRECAUTIONS WHEN USING THIS FIREARM	3	LOADING THE FIREARM	16
CAUTIONS	4	UNLOADING THE FIREARM	17
SAFE HANDLING OF FIREARMS	5	FIRING YOUR DIEMACO MRR	17
LOADING OF FIREARMS	6	LIVE-FIRE TROUBLESHOOTING	19
SAFE SHOOTING OF FIREARMS	6	FIELD STRIPPING	23
CARE & MAINTENANCE OF FIREARMS	6	ADDITIONAL STRIPPING	25
SAFE STORAGE OF FIREARMS	7	REASSEMBLY	26
DIEMACO MRR	8	SLIDING BUTTSTOCK	27
SEMI-AUTOMATIC MODULAR RAIL		SIGHTS - AIMING & ZEROING	28
RIFLE OVERVIEW	8	OPERATING - ARCTIC CONDITIONS	29
SAFETY FEATURES	9	CARE & CLEANING	30
PROVING THE FIREARM "SAFE"	9	DETAILED CLEANING TECHNIQUES	31
LOCATION OF CONTROLS	11	SECURING & STORING YOUR FIREARM	34
FUNCTION OF THE DIEMACO MRR	12	TROUBLE SHOOTING GUIDE	35

INTRODUCTION

For your safety and for the safety of others, whether you are an experienced shooter or have never handled a firearm before, we urge you to read this entire instruction manual before handling the firearm. Shooting firearms is a privilege and a major responsibility. Improper use can have lethal and irreparable consequences. Please take this responsibility seriously.

NOTICES

Colt Canada shall NOT be responsible for death, injury, or damage to property resulting from either intentional or accidental discharge of this firearm, or from its function when used for purposes or subjected to treatment, for which it was not designed. Colt Canada shall not honour claims involving this firearm which result from careless or improper handling, unauthorized modification, adjustment or parts replacement, corrosion, neglect, the use of wrong calibre ammunition, the use of ammunition other than original high quality commercially manufactured ammunition in good condition, or any combination thereof. Colt Canada shall not honour claims involving this firearm for any reason or cause, when such claims are made by other than the original owner.

Before leaving the factory this firearm was test fired, carefully inspected, and packaged. Colt Canada can NOT control product handling after it leaves the factory. Therefore, please examine this firearm carefully at the time of purchase to ensure that it is unloaded and undamaged. The dealer should be pleased to assist you in making this examination and endeavour to answer your further questions.

BEFORE USING THIS FIREARM, READ AND FOLLOW THESE INSTRUCTIONS

WARNINGS

- CARELESS OR IMPROPER HANDLING COULD RESULT IN UNINTENTIONAL DISCHARGE, WHICH COULD CAUSE DEATH, INJURY, OR DAMAGE TO PROPERTY.
- WHEN YOU SQUEEZE THE TRIGGER, EXPECT THE GUN TO FIRE. YOU MUST TAKE FULL RESPONSIBILITY FOR FIRING IT. YOUR CARE CAN AVOID ACCIDENTAL DISCHARGE AND YOU WILL THEREBY AVOID ACCIDENTAL DEATH OR INJURY.
- FAILURE TO OBSERVE THE FOLLOWING PRECAUTIONS COULD RESULT IN DAMAGE TO THE FIREARM AND/OR SERIOUS INJURY TO THE USER.

PRECAUTIONS WHEN HANDLING THIS FIREARM

- **ALWAYS** ensure that the barrel of the firearm is clear of obstruction before use. If the gun is fired with an obstruction in the bore, it may cause a breech explosion.
- **ALWAYS** ensure that the correct ammunition is used in this firearm. Failure to do so could cause a breech explosion.
- **ENSURE** that the cam pin is installed in the bolt carrier group. If the cam pin is not installed, firing the firearm may cause a breech explosion.
- **DO NOT** fire the firearm with water in the barrel. Doing so may cause a breech explosion.

PRECAUTIONS WHEN HANDLING THIS FIREARM [cont]

REMOVE WATER FROM THE BARREL AS FOLLOWS:

- Remove the muzzle cap (if applicable).
- Pull the charging handle rearward 5 to 8 cm and allow the water to drain.
- Point the muzzle down and shake firearm vigorously.

- If necessary, use thumb pressure on the forward assist to seat the round in the chamber. If the cartridge still will not chamber, thoroughly check the bore, chamber and cartridge.
- Ensure that the drain hole in the receiver extension is clear and drain. Clean with a pipe cleaner if necessary.
- If the firearm fails to fire with a live round in the chamber of a hot barrel there is a risk that the round may achieve auto-ignition from exposure to the heat of the barrel (Cook Off). This is a rare occurrence in a semi-automatic firearm and requires a very significant amount of rapid-fire shooting to occur. If this scenario occurs, maintain muzzle control in a safe direction and wait for 15 minutes before ejecting the round.
- If you notice a difference in sound or recoil, STOP FIRING. Check for a bullet in the bore. Firing the firearm with a bullet lodged in the bore could cause a breech explosion.

CAUTIONS

CAREFULLY READ THIS INSTRUCTION MANUAL PRIOR TO LOADING AND FIRING. IT GIVES BASIC ADVICE ON THE PROPER HANDLING AND FUNCTIONING OF THIS COLT CANADA FIREARM.

Your safety, and the safety of others (including your family) depends on your mature compliance with this advice, and your adoption, development and constant employment of safe practices. If you are unfamiliar with firearms, seek further advice through safe handling courses run by your local gun club, range instructor, or similarly qualified organizations.

SAFE HANDLING OF FIREARMS

- **ALWAYS** treat every firearm as if it were loaded.
- **ALWAYS** check to ensure the firearm is NOT loaded: IMMEDIATELY after picking it up.
- **ALWAYS** check to ensure that the firearm is NOT loaded before giving it to another person.
- **IMMEDIATELY** check to make sure that the firearm is NOT loaded when receiving it from another person.
- **NEVER** rely on the firearm's safety mechanism.
- **NEVER** point a firearm at anything you do not intend to shoot regardless of whether the firearm is UNLOADED or on SAFE.
- **NEVER** transport a loaded firearm.
- **NEVER** climb a tree, fence, or obstacle with a loaded firearm.
- **NEVER** consume alcoholic beverages or mind altering drugs before or during the handling of firearms.
- **ALWAYS** abide by safety rules, even when the firearm is unloaded or on SAFE.

LOADING OF FIREARMS

- **ONLY** load a firearm at the destination where you intend to shoot.
- **ALWAYS** use the proper ammunition for your particular firearm.
- **NEVER** chamber a round until ready to shoot.
- **NEVER** leave a loaded firearm unattended.

SAFE SHOOTING OF FIREARMS

- **ALWAYS** wear appropriate ear and eye protection when shooting or observing.
- **ALWAYS** make sure that the target and the area surrounding the target are safe before shooting.
- **ONLY** place your finger on the trigger when you are actually aiming at a safe target and have made the decision to fire.
- **ALWAYS** refer to the Operators Safety and Instruction Manual if your firearm fails to fire.
- **NEVER** shoot a firearm at hard surfaces or water.

CARE AND MAINTENANCE OF FIREARMS

- **ALWAYS** make sure your firearm is NOT loaded before cleaning.
- **ALWAYS** properly maintain your firearm.
- **NEVER** alter or modify your firearm.

SAFE STORAGE OF FIREARMS

- **ALWAYS** make sure your firearm is NOT loaded before storing.
- **ALWAYS** store firearms and ammunition in separately secured locations, so that children and untrained adults cannot gain access to them.

SAFETY DEPENDS ON YOU!

Semi-Automatic Modular Rail Rifle Overview

Diemaco, lightweight, semi-automatic, Modular Rail Rifle (MRR) firearms feature a muzzle compensator, free floating cold hammer forged barrel, and multi-position Magpul MOE buttstock and pistol grip. Firearm configurations include models with 18.6 inch, 16 inch, and 11.6 inch barrel lengths. Both the 16 inch and 11.6 inch configurations utilize Canadian Forces specification chrome lined barrels for increased longevity while the 18.6 inch configuration utilizes an un-lined barrel for increased accuracy. All actions are gas operated, firing from the closed bolt.

Your MRR comes with an Integrated Upper Receiver (IUR) comprised of a monolithic top rail with the side and bottom rail positions implementing the Magpul M-LOK modular locking accessory mounting system. This allows for the perfect alignment of sighting devices and the mounting of a wide range of accessories. Please make sure you read the instructions for any sights or accessories that you choose to utilize and familiarize yourself with their individual safety and installation instructions.

For your safety and for the safety of others, whether you are an experienced shooter, or have never handled a firearm before, we urge you to read this entire instruction manual before handling the firearm.

Safety Features

- **Trigger Guard:** The trigger guard protects the trigger from accidental discharges. The guard may be opened when using heavy gloves, however extra care must be taken when the guard has been opened.
- **Fire Control Selector:** The fire control selector has two positions.
 - When the selector is set to [S], for SAFE: the firearm cannot be fired. The firearm can only be placed on Safe when the trigger mechanism is cocked.
 - When the selector is set to [R] for REPETITION: the firearm will fire once for every time the trigger is squeezed.
- **Bolt Locking:** This firearm can only fire when the bolt is fully locked into the barrel.

Proving the Firearm SAFE [see Figure 1 pg. 10]

CAUTION ALWAYS MAINTAIN MUZZLE CONTROL IN A SAFE DIRECTION.

- Depress the magazine release [1] and remove the magazine [2].
- Pull the charging handle [3] fully rearward, then hold it to the rear.

NOTE Use of the charging handle will cock the action.

NOTE While holding the charging handle to the rear, the bolt carrier group can be locked to the rear by depressing the bottom of the bolt catch [6]. The charging handle can then be returned fully forward. This may be desirable for inspection during range procedures. Be sure to set the fire control selector [5] to [S] once locked open.

- Look in through the ejection port and check to ensure that the receiver and chamber are clear.
- Allow the bolt carrier group to go forward under control.
- Set the fire control selector to [R] and squeeze the trigger [4] to “Fire” the action.
- Take control of any ejected cartridges and return them to the magazine.

If you have locked the bolt carrier group to the rear, unlock it by pulling the charging handle fully rearward before allowing it to go forward under control.

NOTE



Figure 1

Location of Controls

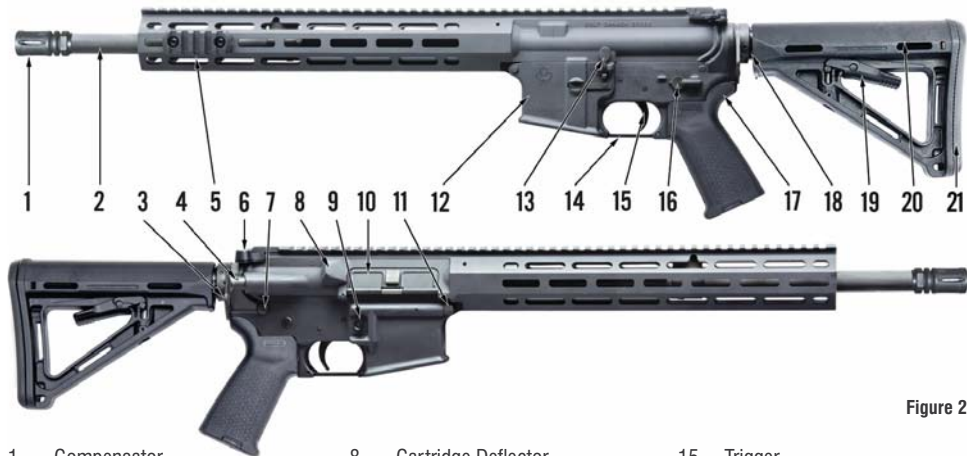

Figure 2

1. Compensator
2. Barrel
3. Sling Loop
4. Forward Assist
5. Rail Adapter
6. Charging Handle
7. Take-down Pin

8. Cartridge Deflector
9. Magazine Release
10. Ejection Port and Cover
11. Pivot Pin
12. Magazine Well
13. Bolt Catch
14. Trigger Guard

15. Trigger
16. Fire Control Selector
17. Pistol Grip
18. Receiver Extension
19. Buttstock Lever
20. Buttstock
21. Butt Pad

Function of the Diemaco MRR

Your Diemaco firearm has a semi-automatic action with the following operation. With a loaded magazine inserted and the fire control selector set to [R], the charging handle is used to cock the action and chamber a round. When the trigger is squeezed, the trigger rotates, disengaging the trigger sear surface from the hammer. The hammer spring drives the hammer forward to strike the firing pin. The firing pin strikes the primer at the base of the cartridge, igniting the primer composition, which ignites the main powder charge.

High pressure gases push the bullet down the barrel where rifling grooves impart a stabilizing spin to the bullet. As the bullet passes the gas port (a small hole in the barrel), gas is tapped off and flows through the gas tube into the bolt carrier chamber, driving the bolt carrier rearward. As the bolt carrier moves to the rear, the firing pin is withdrawn into the bolt, while the cam track in the bolt carrier acts upon the bolt cam pin, causing the bolt to rotate until its locking lugs are no longer in engagement with the lugs of the barrel extension. The bolt is now unlocked and is carried rearward by the bolt carrier.

The extractor holds the base of the spent casing against the face of the bolt, extracting it from the chamber as the bolt travels rearward. Once the spent casing is free of the chamber and exposed to the ejection port, the ejector then ejects the spent casing.

The bolt carrier continues rearward, compressing the return spring and returning the hammer to its cocked position. Rearward motion stops when the buffer assembly strikes the bottom of the receiver extension.

As the bolt moves forward, the bolt feed lugs strip the next round of ammunition from the magazine and direct it forward into the chamber. The hammer is caught and held rearward by the disconnect.

Function of the Diemaco MRR [cont]

As the cartridge seats in the chamber, the extractor snaps over the rim of the cartridge case. Forward motion of the bolt stops, and the bolt locks into the barrel extension, under influence of the carrier cam, as the carrier rides forward over the bolt.

When the trigger is released, the disconnect is rotated back to the point of releasing the hammer while the trigger sear surface rotates in front of the hammer notch. As the hammer is released by the disconnect, it catches on the trigger sear surface, ready for the next firing cycle.

CAUTION

THIS IS A SEMI-AUTOMATIC FIREARM. IT IS IMMEDIATELY LOADED AND READY TO FIRE AFTER EACH SHOT UNTIL THE MAGAZINE IS EMPTY.

FUNCTION TEST

With the magazine removed, and the firearm proved safe, test the function of the firearm after assembly as follows:

- Cock the firearm; set the fire control selector to [S]; and squeeze the trigger: The hammer **SHOULD NOT** be released.
- Set the fire control selector to [R]; squeeze the trigger and hold it to the rear: The hammer **SHOULD** be released.
- With the trigger still at the rear, cock the firearm: the hammer **SHOULD NOT** be released.
- Release the trigger and listen for a “Click” as the disconnect releases the sear.
- Squeeze the trigger again: The hammer **SHOULD** be released.



Figure 3

Ammunition

Diemaco Rifles and Carbines can come in various can be chambered in various ammunition sizing. The chambering information for your rifle or carbine can be found on the top muzzle end of the barrel. See Figure 4.

DANGER



NEVER USE ANYTHING BUT ORIGINAL HIGH QUALITY COMMERCIALY MANUFACTURED AMMUNITION FOR WHICH THE FIREARM IS CHAMBERED. THE USE OF INCORRECT CALIBRE OR HIGH PRESSURED HANDLOADS CAN RESULT IN DAMAGE TO THE FIREARM AND SEVERE PERSONAL INJURY.

CHAMBER IDENTIFICATION



Figure 4

DO NOT FIRE

- Seriously corroded ammunition.
- Dented cartridges.
- Cartridges with loose bullets.
- Cartridges exposed to extreme heat (57°C) until they have cooled.

NOTE

See WARNINGS and CAUTIONS at the beginning of this manual for more about ammunition.

Filling the Magazine

To fill the magazine, use the following procedure, (see Figure 5):

NOTE Use only ammunition for which your firearm is chambered.

- Orient the front of magazine forward.
- Place a round with the bullet oriented forward between the lips of the magazine.
- Press the round down until it is retained by the magazine lips.
- Place the next round on top of the last and repeat until desired number is loaded.



Figure 5

Loading the Firearm [See Figure 1 pg. 10]

- If necessary, press the magazine release [1] and remove the empty magazine.
 - With the magazine [2] oriented forward, Push the magazine into the magazine well until it engages with a positive “Click”.
 - Tug on the magazine to check engagement with the magazine catch.
- If the bolt carrier group is locked to the rear, proceed as follows:**
- Depress the bolt catch [6]. The bolt will slide forward on its own, pushing a cartridge into the chamber and locking the bolt.
- If the bolt carrier group is forward, proceed as follows:**
- Pull the charging handle [3] to the rear.
 - Release the charging handle: **DO NOT** “Ride” the charging handle, let it go forward on its own.

Use of the Forward Assist [see Figure 2 pg. 11]

Pushing on the Forward Assist helps to lock the bolt into the barrel if it does not fully lock on its own. Use of the forward assist will only be helpful on rare occasions, however when it is required it is a good indication that it is time to clean your firearm. If the forward assist does not function using thumb pressure only, thoroughly inspect the firearm.

CAUTION

THE FIREARM IS NOW LOADED WITH A ROUND IN THE CHAMBER: THE HAMMER IS COCKED AND READY TO FIRE.

- Set the fire control selector [5] to “S”.

Loading the Firearm [cont]

WARNING

NEVER LEAVE YOUR FIREARM COCKED AND LOADED WITHOUT THE SELECTOR IN THE “S” POSITION. THE FIREARM COULD EASILY BE FIRED OR DISCHARGE CAUSING DEATH, INJURY OR DAMAGE TO PROPERTY.

- Close the ejection port if you wish. This will open automatically after the first round is fired.

Unloading the Firearm [See Figure 1 pg. 10]

- Ensure that the fire control selector [5] is set to [S].
- Depress the magazine release [1] and remove the magazine [2].
- Pull the charging handle [3] fully rearward, then hold it to the rear.
- Check to ensure that the receiver and chamber are clear.
- Allow the bolt carrier group to go forward under control.
- Set the fire control selector to [R] and squeeze the trigger [4] to “Fire” the action.
- Close the ejection port.
- Take control of any ejected cartridges and return them to the magazine.

Firing Your Diemaco MRR

WARNING

IF YOU NOTICE A DIFFERENCE IN SOUND OR RECOIL: STOP FIRING! THERE COULD BE A BULLET LODGED IN THE BORE. FIRING THE FIREARM WITH A BULLET LODGED IN THE BORE COULD CAUSE A BREECH EXPLOSION AND INJURY TO THE OPERATOR.

Firing Your Diemaco MRR [cont]

WARNING

PRACTICE THE FUNCTION OF YOUR FIREARM, STANCE, AIMING, AND BREATHING WITH THE FIREARM UNLOADED BEFORE USING YOUR FIREARM LOADED.

ALWAYS WEAR HEARING AND EYE PROTECTION DURING FIRING.

KEEP YOUR FIREARM POINTED IN A SAFE DIRECTION.

CAUTIONS

KEEP FINGERS AWAY FROM THE TRIGGER UNLESS FIRING.

KEEP FINGERS AWAY FROM THE EJECTION PORT.

- Grasp the firearm with one hand on the handguard and the other around the pistol grip with your index finger resting along the outside of the trigger guard. Raise the firearm and pull the buttstock firmly into your shoulder. Extend the buttstock if required for comfort or length.

NOTE

See Sliding Buttstock [pg. 27] for information on buttstock adjustment.

- Aim at your target by aligning the front and rear sights.
- Set the fire control selector to [R].
- Place your index finger on the trigger and squeeze gently until the trigger releases the hammer: Repeat this step for each round fired.

Firing Your Diemaco MRR [cont]

- When the magazine is empty, the bolt will stay in the open or rear position. Return the fire control selector to [S] and follow the loading or unloading procedures.

Live-Fire Troubleshooting

If, during firing, you encounter an issue with the firearm's operation, refer to the following troubleshooting procedures. Read through and thoroughly familiarize yourself with the action plan laid out in this section so that you are prepared to safely handle any situations that may occur.

NOTE See TROUBLESHOOTING at the end of this manual for more troubleshooting information.

CHANGE IN SOUND OR RECOIL

This condition could indicate an incomplete propellant burn, a bullet lodged in the bore, or both: STOP FIRING IMMEDIATELY!

WARNING

IF A FIREARM IS FIRED WITH AN OBSTRUCTION IN THE BORE, IT MAY CAUSE A BREECH EXPLOSION RESULTING IN DAMAGE TO THE FIREARM AND/OR SERIOUS INJURY TO THE USER.

Live-fire Troubleshooting [cont]

IMMEDIATE ACTION

Should you notice a change in sound or recoil, the immediate action is as follows:

- Set the fire control selector to [S].
- Remove the magazine.
- Continue to prove the firearm safe and lock the bolt carrier group to the rear using the bolt catch.
- Check for unburnt propellant or a bullet lodged in the bore.
- If there is no bore obstruction, clean out any unburnt propellant.
- Re-load, re-aim, and resume firing.
- If there is a bullet lodged in the bore, **DO NOT** attempt to remove it. Take the rifle to a qualified gunsmith to avoid damage to the firearm during removal.

FAILURE TO FIRE

There are several circumstances that can cause a firearm to fail to fire when the trigger is pulled. Some can be dangerous to the operator if not handled correctly.

IMMEDIATE ACTION

If the firearm fails to fire, the immediate action is as follows:

- Keep the firearm pointed in a safe direction.
- While maintaining muzzle control in a safe direction, tilt the firearm to the left and check the position of the bolt carrier group by looking into the ejection port. Based on its position, follow the appropriate corrective action below.

Live-fire Troubleshooting [cont]

CORRECTIVE ACTIONS

If the bolt carrier group is to the rear, proceed as follows:

- Set the fire control selector to [S];
- Check to see if the magazine is empty;
- Reload;
- Operate the bolt catch;
- Re-aim; and
- Continue firing.

If the bolt carrier group is fully forward:

- Wait 30 seconds while maintaining muzzle control in a safe direction, in case of a hang fire (slow ignition). If a round does not fire in that time, it is unlikely to. Continue the corrective action below.

DURING A HANGFIRE SCENARIO, OPENING THE ACTION IMMEDIATELY CAN LEAD TO THE ROUND NOT BEING LOCKED IN THE CHAMBER DURING IGNITION, POTENTIALLY CAUSING INJURY TO THE OPERATOR.

WARNINGS

IF THERE IS CONCERN THAT THE BARREL MAY BE HOT ENOUGH TO INDUCE A COOK OFF SCENARIO, WAIT 15 MINUTES WHILE MAINTAINING MUZZLE CONTROL IN A SAFE DIRECTION BEFORE PROCEEDING.

NOTE

See WARNINGS and CAUTIONS at the beginning of this manual for more information on “Cook Off” scenarios.

- Check the magazine to ensure that it is fully seated and locked in place.
- Pull the charging handle all the way back and watch for the ejection of a round, or an empty casing.
- If a round or empty casing is ejected, release the charging handle to feed a new round, re-aim and continue firing.
- If no empty casing or round is ejected, release the charging handle and attempt to continue firing.

NOTE

If the firearm fails to fire again, prove the firearm “safe” and refer to TROUBLESHOOTING at the end of this manual.

- If the bolt carrier group is partially forward, pull the charging handle all the way back, lock the bolt carrier group to the rear, and return the charging handle fully forward. Set the fire control selector to [S]. Examine the receiver and chamber of the firearm.
- If a live round or empty casing is in the receiver or chamber, remove the magazine, and clear the obstruction.
- If the receiver and chamber are clear, replace the magazine, operate the bolt catch, re-aim; and continue firing.

Field Stripping [See Figure 6]

CAUTION

WHILE THE UPPER AND LOWER RECEIVER ASSEMBLIES ARE SEPARATED, NEVER PULL THE TRIGGER WITHOUT CONTROLLING THE HAMMER. THIS CAN CAUSE SERIOUS DAMAGE TO YOUR FIREARM.

- Prove the firearm safe and leave the action cocked, with the bolt carrier group forward.
- Set the fire control selector to [S].
- Push the takedown pin [1] all the way to the right until it clicks and then pivot the upper receiver group [2] upward.
- Pull the charging handle [3] rearward to expose the bolt carrier group [4] and remove it.
- Remove the charging handle from its guideway.



Figure 6

FIELD STRIPPING [cont]

[See Figure 7]

- Withdraw the firing pin retaining pin [5] on the carrier.
- Remove the firing pin [6].
- When viewed from the face, rotate the bolt [7] clockwise into the locked position to expose the cam pin.
- Rotate the cam pin [8] 1/4 turn and remove it.
- Remove the bolt from the carrier [9].

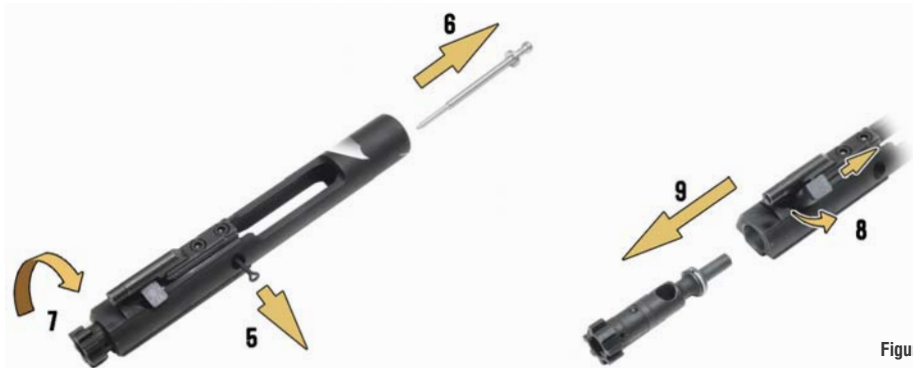

Figure 7

Additional Stripping [Refer to Figure 8 & 9 pgs. 25 & 26]

Figure 8



- Using a suitable punch, remove the extractor pin [1].
- Remove the extractor and spring as an assembly: **DO NOT** separate the spring from the extractor and **DO NOT** remove the elastomeric insert (black rubber) from inside the extractor spring. Ensure that the “D-ring” elastomer [2] is present in the spring group.
- Push the receiver pivot pin [3] all the way to the right.
- Separate the upper and lower receivers.
- Press in on the buffer [4], depress the buffer retainer [5], and release the buffer under control.
- Remove the buffer and return spring [6].

ADDITIONAL STRIPPING [cont]

- If necessary for cleaning, remove the elastomeric insert from the receiver [7].

NOTE

The instructions found under Field Stripping and Additional Stripping are to be performed for the purpose of proper care and cleaning. Any further disassembly should only be performed by a qualified gunsmith to avoid the risk of damage to the firearm or loss of parts.



Figure 9

Reassembly

To reassemble the firearm, follow the steps from ADDITIONAL STRIPPING and FIELD STRIPPING in reverse order. Perform a Function Test after assembly to ensure that the firearm is operating correctly.

Sliding Buttstock [See Figure 10]

ADJUSTMENT

To collapse or extend the buttstock, depress the adjustment lever [1] and slide the stock forward or rearward. The buttstock has intermediate positions for the comfort of the shooter.

REMOVAL

To remove the sliding buttstock, pull down on the release pin [2] forward of the adjustment lever, and slide the buttstock off of the receiver extension.



Figure 10

Sights – Aiming and Zeroing

Please refer to the documentation that came with your sights for care and zeroing procedures.

AIMING TIPS

- Relax, hold steady, and keep the firearm level: **DO NOT** tilt the firearm sideways.
- Keep the tip of front sight in the centre of the rear aperture sight. Focus on the tip of the front sight, not on the target.

ZEROING

- It can be difficult to see your front sight against the black of the target while zeroing, hence you will achieve more consistent results by aiming at “6 o’clock”.
- For Bull’s Eye target shooting, adopt a “6 o’clock hold” on the black and adjust the rear sight until groups of rounds are centred on the centre of the bull’s eye.
- For Point of Aim shooting, adopt a “6 o’clock” hold on the black and adjust the rear sight until groups of rounds are centred on the “6 o’clock” position on the black. This should make your point of aim the same as your point of impact.

Operating – Arctic Conditions [See Figure 11]

When operating in Arctic or Cold conditions, the trigger guard may be opened to obtain easier access to the trigger while wearing thick or arctic mittens or gloves.

- **To open the trigger guard:** Depress the trigger guard plunger and rotate the guard downward against the pistol grip.
- **To close the trigger guard:** Depress the trigger guard plunger and rotate the guard back into place.

WARNING

CARE SHOULD BE TAKEN WHEN THE TRIGGER GUARD IS OPEN, AS THE FIREARM COULD EASILY BE FIRED OR DISCHARGED CAUSING DEATH, INJURY, OR DAMAGE TO PROPERTY.



Figure 11

Care and Cleaning

NORMAL CONDITIONS

- Clean and lubricate with a quality cleaner/lubricant/preservative.

DUSTY AND SANDY CONDITIONS

- Clean the firearm more frequently, at least once a day, and keep the firearm covered when possible.
- Reduce lubrication to a minimum, especially on sliding surfaces.

TROPICAL CONDITIONS

- Inspect, strip, clean, and lubricate the firearm more frequently: at least once a day.
- After handling, wipe the firearm down with an oily cloth to remove perspiration, which will accelerate corrosion.

HOT DRY CONDITIONS

- Clean and lubricate the firearm more frequently.

ARCTIC CONDITIONS

- Clean the firearm and lubricate sparingly.
- Cycle the firearm frequently to prevent the mechanism from freezing up.
- Protect the firearm with a cover when it is kept outside and during periods of non-use.
- If the firearm is moved indoors, clean and lubricate thoroughly to remove condensation.

Detailed Cleaning Techniques

EQUIPMENT AND MATERIALS

Cleaning rod or pull-through, cotton flannel patches, small toothbrush, quality gun cleaning solution, Cleaner/Lubricant/Preservative (CLP), a bronze wire bore brush and a bronze wire chamber brush.

WHEN TO CLEAN

Before Firing: Check to ensure that the barrel and chamber are clean and remove any CLP present in the barrel.

After Firing: Clean your firearm as soon as possible: the job will be easier and there will be less opportunity for corrosion to begin. Check your firearm again within a few days to ensure that no further cleaning is necessary.

Wet Firearms: Anytime your firearm gets wet, clean and dry it as soon as possible.

BORE AND CHAMBER

The bore of the barrel has lands and grooves called rifling. Rifling imparts spin on the bullet as it travels down the barrel and exits the muzzle. Always follow the bore from the chamber toward the muzzle when cleaning the bore.

NOTE

Wire brushes should be used to clean only when required.

Detailed Cleaning Techniques [cont]

CAUTION ENSURE THAT THE FIREARM IS NOT LOADED.

- Use a pull through or cleaning rod with an appropriate size bore brush beginning from the chamber down to and out of the muzzle. The bore brush will follow the rifling in the barrel. Repeat as required.

NOTE **DO NOT** change direction while the brush is in the barrel as the brush could become stuck and/or damaged.

- Apply cleaner/lubricant/preservative to a swab and pass it through the barrel, beginning from the chamber down to and out the muzzle. Repeat as required.
- Attach the larger chamber wire brush to the cleaning rod and dip brush in cleaning solution. Clean the chamber by using a minimum of five plunging strokes and three 360° clockwise rotational strokes.

NOTE Disassemble the bolt carrier group before cleaning.

BOLT CARRIER GROUP

- Clean the gas key on top of the bolt carrier with a cotton swab.
- Clean the vent holes and outer surfaces of the bolt carrier and apply CLP or oil to all bearing and contact surfaces.
- Inspect and apply CLP or oil to the bolt, bolt rings, locking lugs, cam pin, firing pin and firing pin retaining pin. Use a pipe cleaner to clean the firing pin channel.
- Apply CLP or oil to the extractor, extractor pin and spring. Inspect the extractor edge for chips and/or cracks.

Detailed Cleaning Techniques [cont]

NOTE Colt Canada does not recommend removal of the Ejector. Instead follow these techniques.

- Apply 2 or 3 drops CLP or oil to the ejector and depress the ejector in and out.
- Dry excess oil.

UPPER RECEIVER

- Use an oiled bore brush to gently clean around the ends of the gas tube.

NOTE Take care to ensure that you **DO NOT** forcefully deflect the gas tube while cleaning as this could cause premature wear or damage.

- Lightly apply CLP or oil inside the charging handle guide, bore, and chamber.
- Apply 2 drops of CLP or oil to the front sight detent then depress and release the detent to work the oil into the spring.
- Apply CLP or oil to the latch and spring of the charging handle.

NOTE **DO NOT** use a wire brush on ALUMINIUM surfaces such as the receivers as it could cause premature wear and damage. If cleaning is required, use a toothbrush and flannel with the cleaning solution to avoid scratching the surfaces.

LOWER RECEIVER

- Using a toothbrush and pipe cleaner, clean all areas of propellant, residue, and dirt.

Detailed Cleaning Techniques [cont]

- Apply CLP or oil to the trigger mechanism, selector, magazine catch, pivot and takedown pins, detents, and buttstock lever.
- Clean and lightly apply CLP or oil to the inside of the buffer tube, buffer, and buffer spring.

COMPLETION OF CLEANING PROCEDURES

- Wipe all components clean and dry, and inspect for excessive wear, corrosion, or mechanical damage. If any are discovered, have them corrected before firing again.
- Re-assemble the firearm.
- Remove any gun cleaning solution, oil, and finger prints from the outside surfaces of the firearm.

NOTE Moisture from fingers, if left, could start the corrosion process.

Securing and Storing Your Firearm

- Make certain your firearm is safe and secure by following all applicable laws pertaining to the storage of your specific firearm.
- **ALWAYS** store your firearm **UNLOADED**.
- **ALWAYS** store your firearm **UNCOCKED**.
- Store ammunition in a separate, secure location from your firearm.
- Lightly coat the outside of the firearm with CLP or oil.
- If storing for a long period of time to avoid corrosion, apply CLP or oil to a swab and pass it through the barrel, beginning from the chamber down to and out the muzzle. Clean the CLP or oil out of the barrel before firing again.

TROUBLE SHOOTING

PROBLEM	COMMON CAUSE	CORRECTIVE ACTION
Firearm fails to fire	- Fire control lever on [S]	- Move lever to [R]
	- Improper assembly of firing pin	- Assemble correctly (retaining pin goes to the rear of the large shoulder of the firing pin)
	- Bolt unlocked	- Check chamber, barrel, locking lugs and ammunition
	- Excessive amount of oil in firing pin hole	- Clean with pipe cleaner
	- Defective ammunition	- Remove and discard
	- Too much carbon on firing pin or in firing pin hole	- Clean
Bolt won't unlock	- Dirty bolt	- Clean
	- Burred bolt	- Refer to Firearms Technician
Failure to extract	- Broken Extractor Spring	- Refer to Firearms Technician
	- Dirty or corroded ammunition	- Remove & discard
	- Carbon in chamber	- Clean the chamber
	- Fouling or carbon in the extractor recess or lip	- Clean

[cont]

TROUBLE SHOOTING [cont]

PROBLEM	COMMON CAUSE	CORRECTIVE ACTION
Failure to feed	- Dirty or corroded ammunition	- Clean or discard
	- Dirty magazine	- Clean
	- Defective magazine	- Replace
	- Too many rounds in the magazine	- Remove the excess ammunition
	- Movement of buffer spring is restricted	- Disassemble and clean the buffer and return
Double feed	- Defective magazine	- Replace
Round will not chamber	- Defective magazine	- Replace
Bolt will not lock	- Dirty or corroded ammunition	- Clean or replace
	- Damaged ammunition	- Replace
	- Carbon in chamber	- Clean
	- Damaged gas tube	- Refer to Firearms Technician
	- Obstruction in bore	- Clear obstruction

TROUBLE SHOOTING [cont]

PROBLEM	COMMON CAUSE	CORRECTIVE ACTION
Failure to eject	- Dirt, corrosion or carbon buildup in the barrel locking lugs	- Clean
	- Faulty magazine	- Replace
	- Broken ejector spring	- Refer to Firearms Technician
	- Movement of the buffer is restricted	- Remove and clean (before assembling the bolt to the carrier, ensure that the gas tube fits into the carrier key and that the carrier moves freely within the upper receiver)
	- Gaps in the bolt rings not staggered	- Stagger the ring gaps
	- Carbon or dirt in the interior of the gas key or on the exterior of the gas tube	- Clean
Bolt fails to lock after the last round has fired	- Dirty or corroded bolt latch	- Clean
	- Faulty magazine	- Replace
	- Dirt in the barrel extension	- Clean

[cont]

TROUBLE SHOOTING [cont]

PROBLEM	COMMON CAUSE	CORRECTIVE ACTION
Bolt fails to lock after the last round has fired	- Dirty or corroded bolt latch	- Clean
	- Faulty magazine	- Replace
	- Dirt in the barrel extension	- Clean
Fire control selector binds	- The selector is dry	- Lubricate
	- Dirt or sand under the trigger	- Clean
Misfire	- Faulty ammunition	- Replace
	- Faulty firing mechanism.	- Refer to Firearms Technician

FIREARM RECORD

Model _____

Serial No. _____

Calibre _____

Purchased from _____ Date _____

Type	Date



PART NO. 17274S-EN

**ALL QUESTIONS OR CONCERNS REGARDING YOUR PRODUCT
OR THIS MANUAL CAN BE MADE TO:**

PRODUCT SUPPORT ENGINEERING - TECHNICAL PUBLICATIONS

COLT CANADA CORPORATION

1036 Wilson Avenue, Kitchener, Ontario CANADA, N2C 1J3

Tel: 519-893-6840

Email: info@coltcanada.com

WWW.COLTCANADA.COM

2018-07-31

© 2018 COLT CANADA CORPORATION. ALL RIGHTS RESERVED.

PRINTED IN CANADA 

